



# TRIKKE™ E2



**⚠ NOTE:** The Trikke E2 must be traveling up to 3 mph before motor will engage. Kick start up to 3 mph while applying the throttle to engage motor.

## OWNER'S MANUAL

**Read and understand this entire manual before allowing child to use this product!**

**For assistance contact Razor. DO NOT RETURN TO STORE.**

**NOTE: Manual illustrations are for demonstration purposes only. Illustrations may not reflect exact appearance of actual product. Specifications subject to change without notice.**

**Please have your 19 character product I.D. code ready before contacting Razor for warranty assistance and/or replacement parts.**

**Product I.D. Code:** \_\_\_\_\_ - \_\_\_\_\_ - \_\_\_\_\_

# CONTENTS

Safety Warnings .....	1	Pre-Ride Checklist/Usage .....	6-8
Before You Begin.....	2	Repair and Maintenance.....	9-10
Assembly and Setup.....	3-4	Trikke E2 Parts.....	11
Charging the Battery.....	5	Warranty .....	14

## SAFETY WARNINGS

**! WARNING:** Riding a Razor Trikke™ E2 electric product does present potential risks and caution is required. Like any riding product, this product has inherent hazards associated with its use (for example, falling off or riding it into a hazardous situation). Like any riding product, the Razor Trikke E2 is intended to move and it is therefore, of course, possible to lose control or otherwise get into dangerous situations. Both children and adults responsible for supervising them must recognize that if such things occur, a rider can be seriously injured or die, even when using safety equipment and other precautions. **RIDE AT YOUR OWN RISK AND USE COMMON SENSE.**

**! WARNING: PARENTAL AND ADULT RESPONSIBILITY AND SUPERVISION IS NECESSARY:** Because products like this can and do present potential hazards plainly associated with their use, it is well recognized THE NEED FOR EXERCISE OF PARENTAL RESPONSIBILITY IN SELECTING RIDING PRODUCTS APPROPRIATE TO THE AGE OF A CHILD, OR PARENTAL SUPERVISION IN SITUATIONS IN WHICH CHILDREN OF VARIOUS AGES MAY HAVE ACCESS TO THE SAME RIDING PRODUCTS, IS IMPORTANT. Not every product is appropriate for every age or size of child, and different age recommendations are found within this category of product which are intended to reflect the nature of the hazards and the expected mental or physical ability, or both, of a child to cope with the hazards.

**The recommended rider age is 8 and older.** Any rider unable to stand comfortably on the product should not attempt to ride it. A parent's decision to allow his or her child to ride this product should be based on the child's maturity, skill and ability to follow rules.

**Keep this product away from small children and remember that it is intended for use only by persons who are, at a minimum, completely comfortable and competent while operating the product.**

Persons with any mental or physical conditions that may make them susceptible to injury, impair their physical dexterity or mental capabilities to recognize, understand, and follow safety instructions and to be able to understand the hazards inherent in its use, should not use or be permitted to use products inappropriate for their abilities. Persons with heart conditions, head, back or neck ailments (or prior surgeries to these areas of the body), or pregnant women, should be cautioned not to operate such products.

**DO NOT EXCEED THE WEIGHT LIMIT OF 120 lbs (54 kg). Rider weight does not necessarily mean a person's size is appropriate to fit or maintain control of the Razor Trikke E2.**

### CHECK AND MAINTAIN SAFE CONDITIONS

Before use, check to confirm that any and all chain guards or other covers and guards are in place and in serviceable condition. Check that the brake is functioning properly, and that tires are in good condition. The product should be maintained and repaired in accordance with the manufacturer's specifications, using only the manufacturer's authorized replacement parts, and should not be modified from the manufacturer's original design and configuration.

### ACCEPTABLE RIDING PRACTICES AND CONDITIONS

**Always check and obey any local laws or regulations, which may affect the locations where the Razor Trikke E2 may be used. Keep safely away from cars and motor vehicle traffic at all times, and only use where allowed and with caution.**

Do not activate the speed control on the hand grip unless you are on the product and in a safe, outdoor environment suitable for riding.

The normal powered top speed of this product will be approximately 10 mph (16 kmh), which can be affected by conditions such as rider weight, inclines, tire inflation and battery charge level. Avoid excessive speeds that can be associated with downhill rides.

Do not make sudden sharp turns or apply your body weight on the handlebars when turning. Such actions could cause sudden "jack-knifing" or stops, which

could cause falls. Do not do "wheelies" or pull up on the handlebars when riding, as this could cause the rider to slip off the front platforms.

Maintain a hold on the handlebars with both hands at all times. Do not touch the brakes or motor on your product when in use or immediately after riding as these parts can become very hot.

Ride defensively. Watch out for potential obstacles that could catch your wheel or force you to swerve suddenly or lose control. Be careful to avoid pedestrians, skaters, skateboards, scooters, bikes, children or animals who may enter your path, and respect the rights and property of others.

The Razor Trikke E2 is intended for use on flat, dry surfaces, such as pavement or level ground, without loose debris, such as sand, leaves, rocks or gravel. Wet, slick, bumpy, uneven or rough surfaces may impair traction and contribute to possible accidents. Do not ride in mud, ice, puddles or water. Watch out for potential obstacles that could catch your wheels or force you to swerve suddenly or lose control. Avoid sharp bumps, drainage grates, and sudden surface changes.

Do not attempt or do stunts, tricks or ride/roll backwards on your Razor Trikke E2. It is not made to withstand abuse from misuse, such as jumping, curb grinding or any other type of stunts. Racing, stunt riding, or other maneuvers, such as trying to ride backwards, also enhance risk of loss of control, or may cause uncontrolled rider actions or reactions.

- Never allow more than one person at a time to ride the Razor Trikke E2.
- Do not ride at night or when visibility is limited.
- Never use near steps or swimming pools.
- Do not allow hands, feet, hair, body parts, clothing, or similar articles to come in contact with moving parts, wheels, or drivetrain, chain while the motor is running.
- Never use headphones or a cell phone to talk or text when riding.
- Never hitch a ride with a vehicle.

Do not ride the Razor Trikke E2 in wet or icy weather and never immerse it in water, as the electrical and drive components could be damaged by water or create other possibly unsafe conditions. Never risk damaging surfaces, such as carpet or flooring, by use indoors.

### PROPER RIDING ATTIRE

Always wear proper protective equipment, such as an approved safety helmet (with chin strap securely buckled), elbow pads and kneepads. A helmet may be legally required by local law or regulation in your area. A long-sleeved shirt, long pants, and gloves are recommended. Always wear athletic shoes (lace-up shoes with rubber soles), never ride barefooted or in sandals, and keep shoelaces tied and out of the way of the wheels, motor and drive system.

### USING THE CHARGER

The charger supplied with the Razor Trikke E2 should be regularly examined for damage to the cord, plug, enclosure and other parts. In the event of such damage, the product must not be charged until the charger has been repaired or replaced.

- Use only with the recommended charger.
- Use caution when charging.
- The charger is not a toy. Charger should be operated by an adult.
- Do not operate charger near flammable materials.
- Unplug charger and disconnect from the product when not in use.
- Do not exceed charging time.
- Always disconnect from the charger prior to wiping down and cleaning your product with damp cloth.

**BE SURE TO READ AND UNDERSTAND THE "USAGE" SECTION OF THIS MANUAL. FAILURE TO USE COMMON SENSE AND HEED ALL WARNINGS AND INSTRUCTIONS INCREASES RISK OF SERIOUS INJURY. USE WITH APPROPRIATE CAUTION AND SERIOUS ATTENTION TO SAFE OPERATION.**

# BEFORE YOU BEGIN

Remove contents from box. Remove the packaging separators that protect the components from damage during shipping. Inspect the contents of the box for scratches in the paint, dents or kinked cables that may have occurred during shipping. Because the scooter is 50 percent assembled and packed at the factory, there should not be any problems, even if the box has a few scars or dents.

**MAKE SURE POWER SWITCH IS TURNED "OFF" BEFORE CONDUCTING ANY ASSEMBLY OR MAINTENANCE PROCEDURES.**

## Estimated Assembly and Set-Up Time

Allow up to 30 minutes for assembly, not including initial charge time. Two people are recommended for assembly. Allow up to 12 hours for initial charge (see page 5 for charging information).

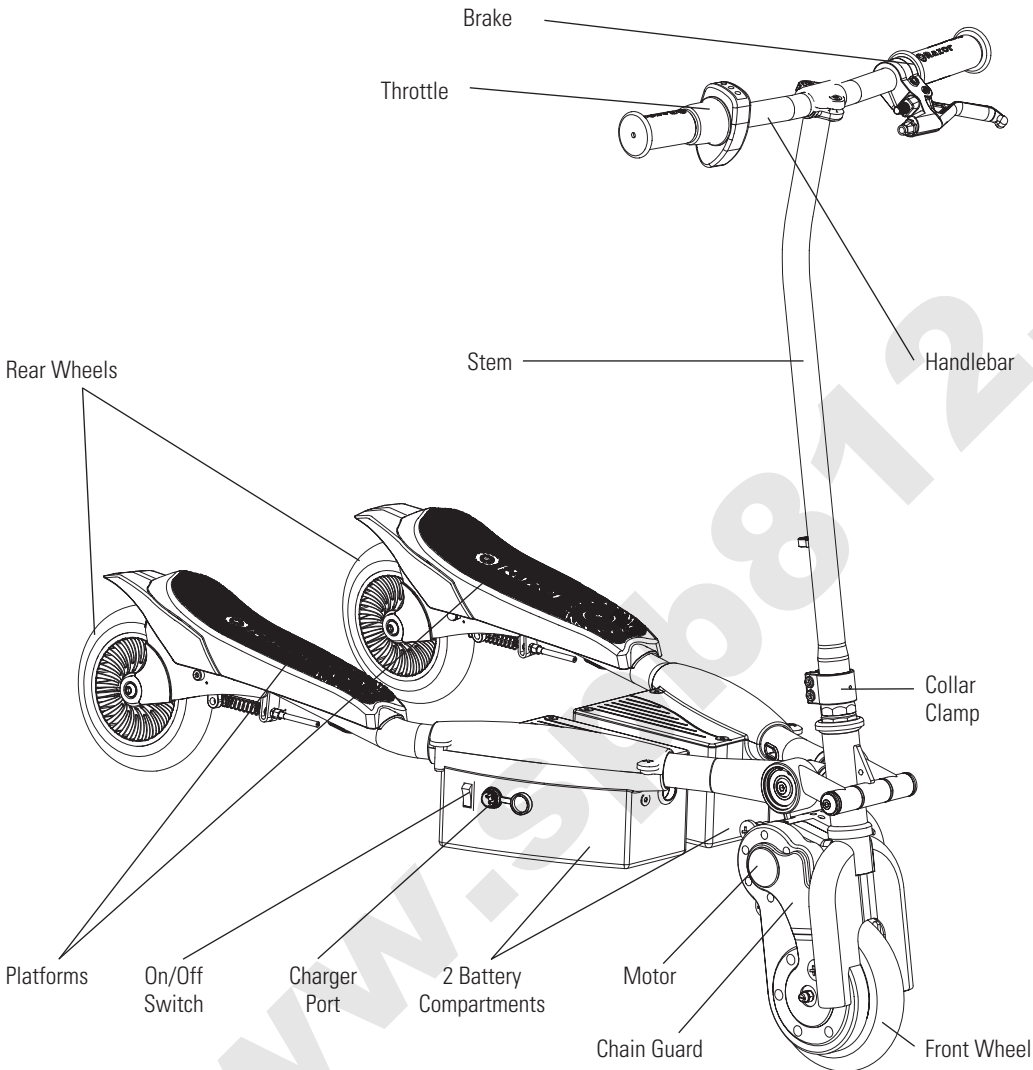

**⚠ WARNING:**  
DO NOT USE NON-RAZOR PARTS WITH YOUR RAZOR ELECTRIC SCOOTER. The scooter has been built to certain Razor design specifications. The original equipment supplied at the time of sale was selected on the basis of its compatibility with the frame, fork and all other parts. Certain aftermarket parts may or may not be compatible and may void your warranty.

**Note:** Trikke E2 must be moving at 3mph/5kmh while applying the throttle to engage motor.

## Product ID Locations:

See locations to the left

1. Stem
2. Battery Tray
3. Charger (not shown)
4. UPC Side of Box (not shown)

## Required Tools

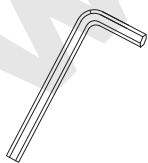

Two (2) 5mm Allen Wrenches (Included)



8mm and 13mm Open Wrenches (Not Included)

# ASSEMBLY AND SET-UP

## □ Attaching the Handlebars

**Tools Required:** 5mm Allen wrench

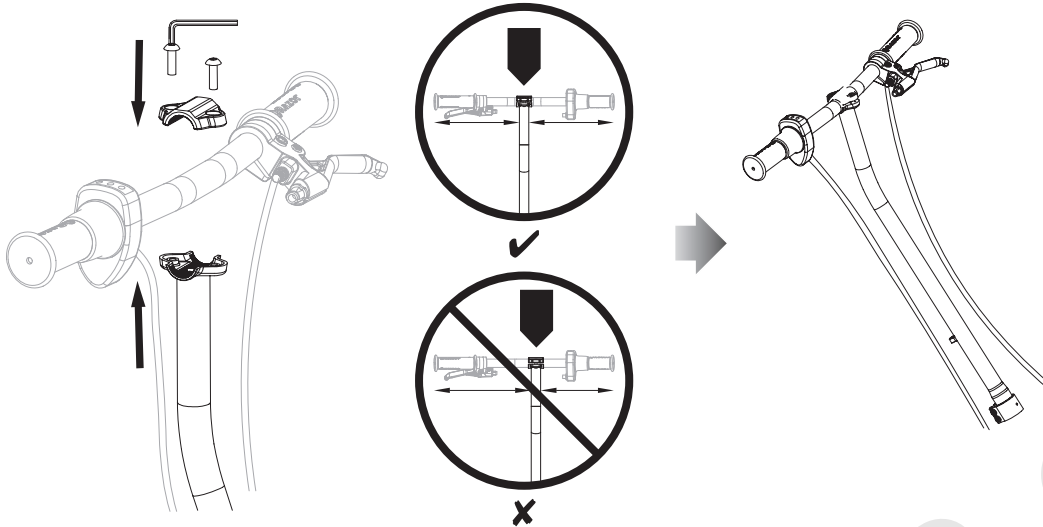

**1** Using a 5mm Allen wrench, remove the 2 bolts on the handlebar clamp.

**2** Center the handlebars onto the stem. Make sure the arc on the handlebars is facing outward and the arc of the stem is facing inward.

**3** Align the holes on the handlebar clamp with the holes on the stem and tighten bolts until handlebars are securely in place.

## □ Attaching the Leg Tubes

**Tools Required:** 5mm Allen wrench

Place battery compartments on level surface, so leg tubes are even. You may use wedge packing material or table.

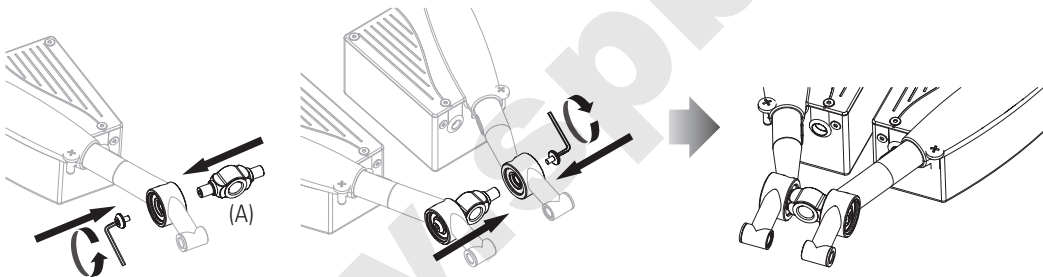

**1** Insert the rotational connector (A) into the right leg tube as shown. Using a 5mm Allen wrench, slightly tighten bolt to hold connector (A) in place.

**2** Attach the left leg tube to the other side of the rotational connector. Using a 5mm Allen wrench, slightly tighten bolt to hold leg tube in place.

**3** Adjust the rotational connector so the opening is positioned as shown.

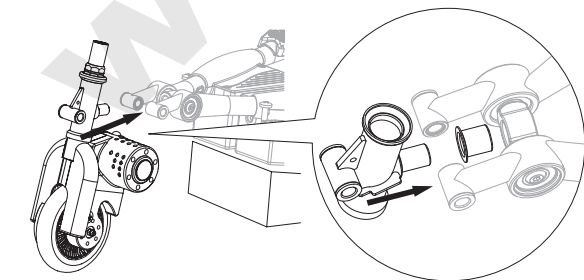

**4** Insert the front fork into the rotational connector.

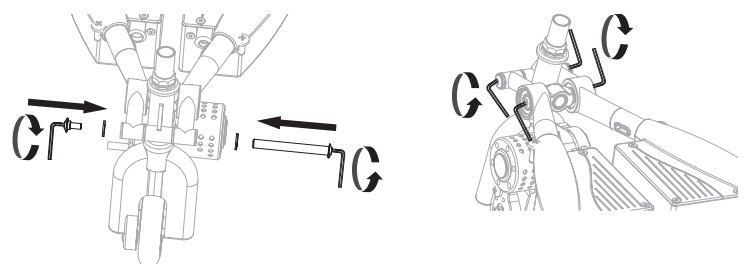

**5** Insert coupling bolt as shown and tighten using two (2) 5 mm Allen wrenches until secure.

# ASSEMBLY AND SET-UP

## □ Attaching the Stem

**Tools Required:** 5mm Allen wrench

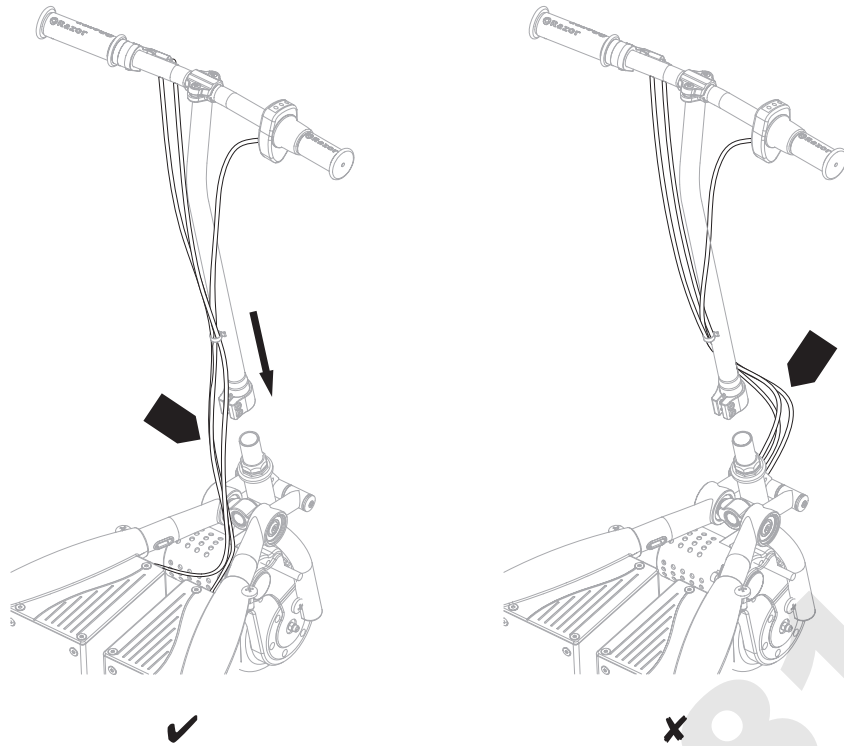

**1** Slide stem onto the front fork. Make sure throttle and brake cables are not touching the rotational corrector.

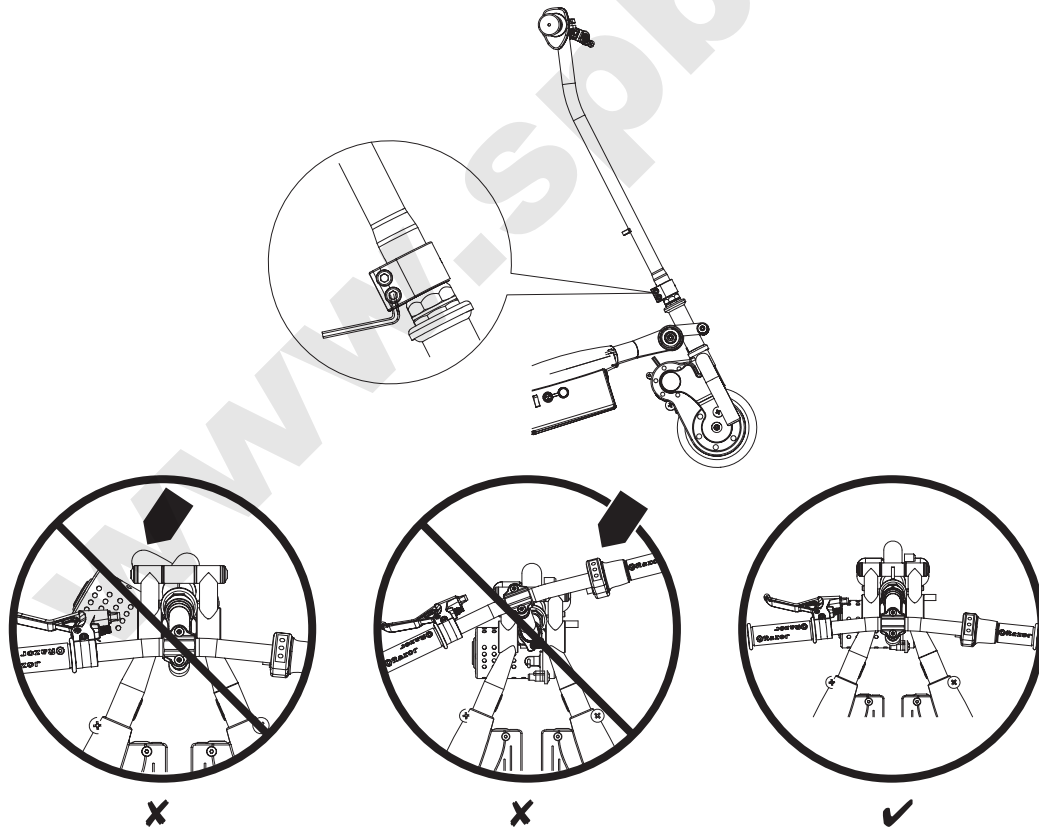

**2** Align the front wheel with handlebars using a 5mm Allen wrench. Tighten bolts on collar clamp until collar clamp is secure.

**Note:** Make sure the cables/wires are out of the way before inserting the stem in the fork.

**⚠ WARNING:** Failure to properly tighten the collar clamp may allow the handlebars to dislodge while riding and may cause you to lose control and fall. When correctly tightened, the handlebars will not rotate out of alignment with the front wheel under normal circumstances.

**Note:** The cable and wire assembly from the handlebar must not wrap around the stem or handlebar. Sharp bends or twisting of the brake cable can cause the brakes to malfunction.

# CHARGING THE BATTERY

## □ Charging the Battery

Charge the battery prior to use.

- Initial charge time: 12 hours.
  - Recharge time: up to 12 hours, even if the light turns green. Recommended maximum charging time is 24 hours.
  - Always charge the battery immediately after riding.
  - Fully charge battery before storing for extended periods of time.
  - Unplug charger from the wall outlet when not in use.
  - Failure to recharge battery periodically may result in a battery that will not accept a charge.
  - Make sure scooter power switch is turned **OFF** when unit is not in use. If the power switch is left on for an extended period of time, the battery may reach a stage at which it will no longer hold a charge.
  - To ensure long battery life, never store the product in freezing or below freezing temperatures! Freezing will permanently damage the battery.
- Run time: Up to 40 minutes of continuous ride time. Run time may vary depending on riding conditions, climate and/or proper maintenance.
  - Constant stopping and starting may shorten ride time.
  - Average battery life for a properly maintained unit is approximately 250 charge/discharge cycles.

Charger

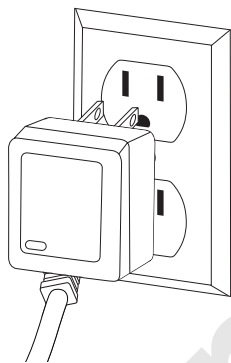
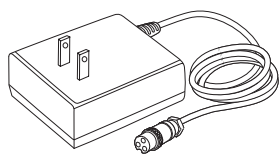

**1** Plug the charger into a wall outlet. If the lights on charger do not light up, check the power to the outlet. If necessary, try a different outlet.

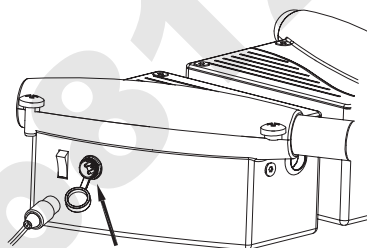

**2** Turn the power switch OFF before charging. Plug the charger into the charger port on the side of the battery compartment.

### **⚠ WARNING:**

Rechargeable batteries are only to be charged under adult supervision. Always disconnect your scooter from the charger before cleaning with damp cloth.

**Note:** If your charger does not look like the one illustrated, your unit has been supplied with an alternative charger. The specifications and charging procedure would not change.

The charger has a small window with one LED light to indicate the charge status. Refer to the illustration on the charger unit for the actual "charging" and "charged" status indications for your model charger.

Chargers have built-in over-charge protection to prevent battery from being over-charged.

Charger may get warm during use. This is normal for some chargers and is no cause for concern. If your charger does not get warm during use, it does not mean that it is not working properly.

### **⚠ WARNING:**

Battery charge can deplete over time. Periodically recharge battery when not in use.

## PRE-RIDE CHECKLIST



### Brake

Check the brakes for proper function. When you squeeze the lever, the brake should provide positive braking action. Make sure that brakes are not rubbing.



### Frame, Fork and Handlebars

Check for cracks or broken connections. Although broken frames are rare, it is possible for an aggressive rider to run into a curb or wall and wreck, bend or break a frame. Get into the habit of inspecting your scooter on a regular basis.



### Wheels

Periodically inspect the wheels for excess wear.



### Hardware

Check all parts such as nuts, bolts, cables, fasteners, etc. to ensure they are secure and assembled correctly. If the unit is damaged do not ride. Reference "Safety Warnings" on page 1 of this manual.



### Laws and Regulations

Always check and obey any local laws or regulations.



### Insurance

Do not assume that your existing insurance policies necessarily provide coverage for use of this product. Check with your insurance company for information regarding insurance.

## USAGE

This is a motorized three-wheeled product and riders must familiarize themselves with the characteristics and proper use of the product. It is not "just like a bicycle," it is not "just like a scooter," and it is not "just like a tricycle." The motor drives the front wheel and riders must learn, practice and understand the proper use of this product to best, and safely, enjoy it.

**Note:** The Trikke E2 must be traveling up to 3mph before motor will engage. Kick start up to 3mph while applying the throttle to engage motor.

### Starting the Trikke E2

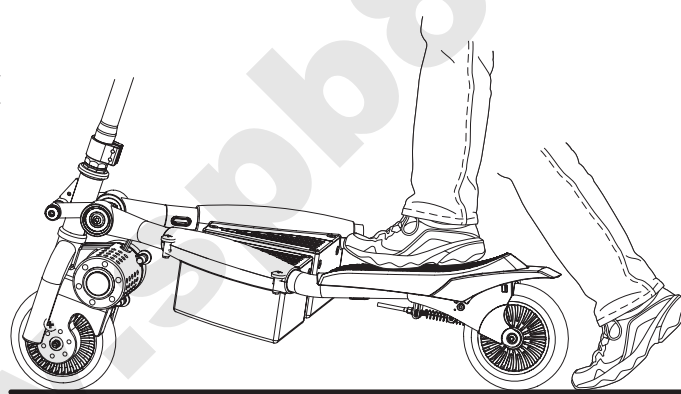
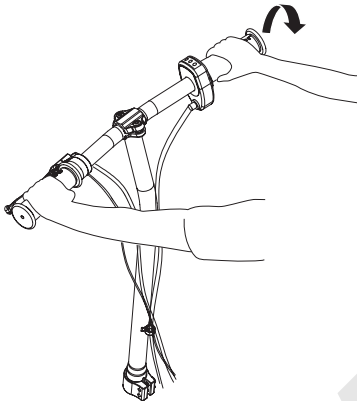

### Stopping the Trikke E2

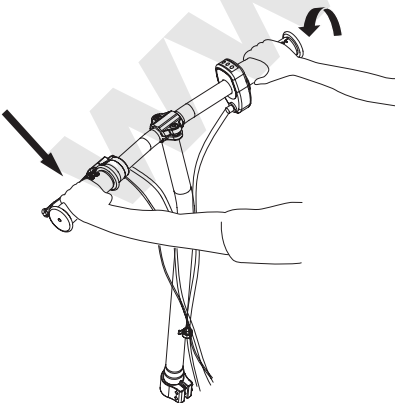

## □ Learn and Practice Weight Distribution and Safety



### OPTIMAL RIDING POSITIONS

Remember, it is the front wheel which mechanically powers the Razor Trikke E2. When accelerating, it is therefore important to place weight on the front wheel to maximize traction and control, as shown in the picture. Keep most of your weight on your toes, feet positioned in front of the platform.

Once you and your Razor Trikke E2 are in motion, return to your normal posture. Be careful not to lean too far back or shift your weight behind the rear wheels. This warning is especially important for drivers who do not have good coordination, or are slow to react to an unexpected event.

The best way to ensure you are always well positioned during normal riding (and to minimize the risk of the product pulling a wheelie), is to distribute your weight evenly between the front and rear wheels, keeping your weight on your toes and putting your feet up to the front of the platforms.

To brake more effectively, shift your weight back over your heels, over the rear wheels, as shown in the picture, but be careful not to lean too far back. Apply the brakes and distribute your weight evenly over each rear wheel for maximum braking efficiency. If you take the weight off of the platforms during braking you may cause the wheel to lose contact with the ground and lock.

Avoid leaning too far over the handlebars - the rider must maintain balance on their feet, not leaning on the handlebars. The legs should be slightly bent to absorb impact, balance the body and ensure constant contact with the platforms.

Avoid leaning your body back, supporting yourself on your heels, or stepping behind the center of the rear wheels and pulling the handlebars back, because this way you will inevitably reduce the weight of the front wheel losing traction and control, and you may fall back and have an accident.

Another reason for a balanced weight distribution is to ensure a better use of traction (front and rear tires) with no spinning or skidding during accelerations and braking.

### PRACTICE SAFE RIDING

Proper use of the handlebars, and especially how to push it to the left and right, is vital for your safety. Because the front wheel is designed to trail the fork, the handlebar tends to turn in the direction you tilt the product. Unlike a bicycle, which tends to follow a straight line, the front wheel will actually accentuate the turn. Because of this condition, less experienced riders should pay special attention while driving. Turning the handlebars too far, and allowing the front wheel to move quickly to the side, may cause the product to stop suddenly ("jack-knifing"), throwing the rider from the product, which may cause injury. Always maintain firm control over the handlebars with both hands, never drive with just one hand or no hands. **The Razor Trikke E2 required both hands on the handlebars at all times.**

Beginner riders have a tendency to apply excessive force on the handlebars, making sudden movements, throwing their weight from one side to another. What propels the product forward manually is the leaning of the product, a combination of turning and leaning of the steering column, and not just pushing the handlebars from side to side. It is better to think in terms of more leaning and less turning. Motion and trajectory in large "S" turns are best for beginners.



# USAGE

## DOWNHILL AND RIDER-ASSISTED RIDING

The Razor Trikke E2 is intended to be primarily powered by its electric motor and does not “require” the rider to use the unique cambering practices associated with manually operated Trikke products for successful riding. The product may be operated to take some advantage of the those cambering principles, though, but riders are encouraged to practice these principles cautiously and carefully. We recommend that you take time to familiarize yourself with the product and to gradually explore the limits of performance with each ride.

This is especially important before attempting climbs or steep descents. Riding uphill and downhill are advanced and require you to be fully competent before even trying and Razor emphasizes that the product should be used by young riders only on flat, level ground to emphasize safety.

Although the Razor Trikke E2 is designed to primarily use electrical power, the product still can be assisted by Trikke Tech, Inc.’s technology allowing conservation of angular momentum, the basic physical principle used to add body power to the Razor Trikke E2. Turning, weight transfer and movement of the rider can help propel the product forward. The painstaking research and development of Trikke Tech eventually combined its body-propulsion techniques and technology with an electric product, creating a totally new experience. The Razor Trikke E2 adopts these principles for younger riders, allowing some degree of “rider-assist,” which young riders may learn to achieve.

Do not be discouraged if you do not get a reasonable result within minutes, as this is an entirely new product, which requires some new skills. Riders who are accustomed to skiing or skating normally learn in minutes - and remember, the Razor Trikke E2 can be operated solely by relying on the electric power, so there is no rush to depend on trying to do too much, too soon. Learn by practice.

A new rider should become comfortable and proficient with standing on the product and operating the Razor Trikke E2 in “full electric” mode before exploring the “manual assist” riding techniques. **Adult supervision and assistance is particularly important when young riders explore these riding techniques.** It is especially important to establish a proper driving position so that rider weight is evenly distributed between front and rear wheels. Beginners tend to un-weight the front of the product. This can be dangerous because the rider can fall back and be injured. Position feet on the center of the platforms and ride supporting weight on toes; this will help balance the weight with the front wheel. Furthermore, properly positioned, the handlebar height should force the rider to lean a little forward. This position will result in more stability, control and quick brake response. Never lean back or pull back on the handlebar.

You are now turning the wheel from one side to another to generate forward movement and establishing a rhythm, even if the electric motor is being used.

- 1. TILT THE STEERING COLUMN RIGHT WHILE TURNING THE WHEEL TO THE RIGHT;**
- 2. TILT STEERING COLUMN LEFT WHILE TURNING THE WHEEL TO THE LEFT. KEEP THIS CADENCE 1, 2, 1, 2, 1, 2...**

When you add synchronized movements from the rear wheels too, it will essentially generate forward thrust. It may take a while for young riders to get a coordinated package of turn and lean, but those who have experience with skiing or skating, will immediately feel the similarities.

The combination of these techniques will be a new experience, but be assured that time will help riders develop a smooth and coordinated movement.

Enjoy the added fun of learning to manually add some power to the Razor Trikke E2’s electric ride, but also be careful and practice safe riding. Be sure to check the Trikke website at [www.trikke.com](http://www.trikke.com) for more tips and guidance.

# REPAIR AND MAINTENANCE

Turn power switch "OFF" before beginning repair or maintenance:

- Read the instructions
- Remove Charger Plug
- Turn the power switch off
- Secure the unit under repair
- Exercise caution around exposed parts
- Contact Razor customer service if unsure about any repair or maintenance

## □ Adjusting the Brakes

**Tools Required:** 8mm wrench

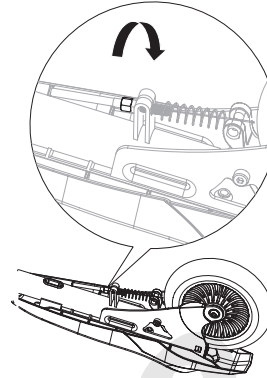
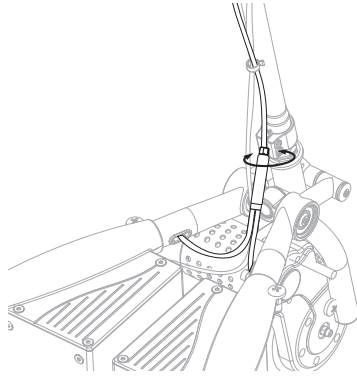
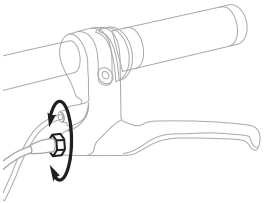

**1** To adjust the brake cable tension, thread the brake lever adjuster in or out 1/4 to 1/2 turn until the desired brake adjustment is attained. Most adjustments are complete at this step. If brake needs further adjustment, proceed to step 2.

**2** Using an 8mm wrench, loosen nut on brake line (by caliper clamp) and adjust tension. If brake still needs further adjustment proceed to step 3.

**3** Using an 8mm wrench, loosen up the barrel adjuster that is holding the brake cable and adjust tension accordingly.

## □ Rear Wheel Replacement

**Tools Required:** Two (2) 5mm Allen wrenches

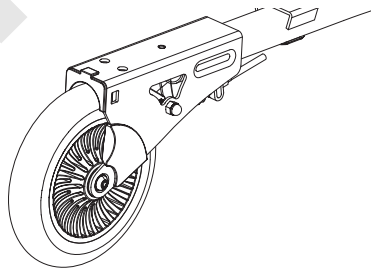
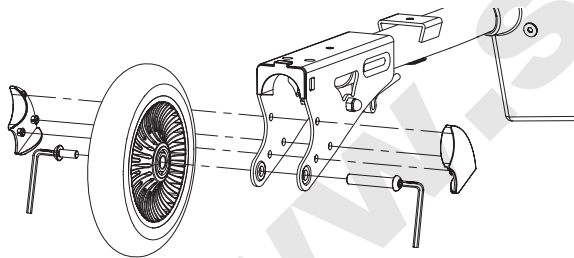

**1** Using two (2) 5mm Allen wrenches, loosen axle bolt and remove wheel. Install new wheel, re-insert axle bolt and tighten securely.

## REPAIR AND MAINTENANCE

### ❑ Battery Care and Disposal

Do not store in freezing or below freezing temperatures. To properly maintain your battery and ensure maximum battery life, carefully read the "Charging the Battery" section on page 5 of this owner's manual.



CONTAINS SEALED LEAD ACID BATTERIES. BATTERIES MUST BE RECYCLED.

**Disposal:** Your Razor product uses sealed lead-acid batteries which must be recycled or disposed of in an environmentally safe manner. Do not dispose of a lead-acid battery in a fire. The battery may explode or leak. Do not dispose of a lead-acid battery in your regular household trash. The incineration, land filling or mixing of sealed lead-acid batteries with household trash is prohibited by law in most areas. Return exhausted batteries to a federal or state approved lead-acid battery recycler or a local seller of automotive batteries. If you live in Florida or Minnesota, it is prohibited by law to throw away lead-acid batteries in the municipal waste stream.

### ❑ Charger

The charger supplied with the electric scooter should be regularly examined for damage to the cord, plug, enclosure and other parts and in the event of such damage, the product must not be charged until it has been repaired or replaced.

Use ONLY the charger supplied with this product or a recommended replacement specified by Razor.

### ❑ Wheels

Wheels and drive system are subject to normal wear and tear. It is the responsibility of the user to periodically inspect wheels for excess wear and adjust and replace drive train components as required.

### ❑ Replacement Parts

For the complete selection of replacement parts visit [www.razor.com](http://www.razor.com).

### ❑ Repair Centers

For a list of authorized Razor repair centers:

- Call 866-467-2967 for the center nearest you.

**⚠ WARNING:** If a battery leak develops, avoid any contact with leaking acid and place the damaged battery in a plastic bag. Refer to the disposal instructions at left. If acid comes into contact with skin or eyes, flush with cool water for at least 15 minutes and contact a physician.

**⚠ WARNING:** Battery posts, terminals and related accessories contain lead and lead compounds. **Wash your hands after handling.**

# TRIKKE E2 PARTS

Keep your scooter running for years with genuine Razor parts. Visit our website or e-mail us for more information on spare part availability. (Specifications subject to change without notice.)

- |                                       |                                      |                                       |
|---------------------------------------|--------------------------------------|---------------------------------------|
| 1. Handlebar Grips                    | 10. Battery Bracket                  | 19. Motor Cover                       |
| 2. Brake Lever Assembly               | 11. Battery Compartment (Left/Right) | 20. Motor                             |
| 3. Handlebar                          | 12. On/Off Switch                    | 21. Coupling Bolt                     |
| 4. Handlebar Clamp                    | 13. Charger Port                     | 22. Rotational Connector Bolts (2)    |
| 5. Throttle                           | 14. Chain Guard                      | 23. Rotational Connector with Bushing |
| 6. Platform (Left/Right)              | 15. Chain Tensioner                  | 24. Headset (Upper/Lower)             |
| 7. Rear Wheels (Left/Right)           | 16. Chain                            | 25. Stem                              |
| 8. Battery (Left/Right) - 24v (2-12v) | 17. Front Fork                       | 26. Leg Tube (Left/Right)             |
| 9. Controller                         | 18. Front Wheel                      |                                       |

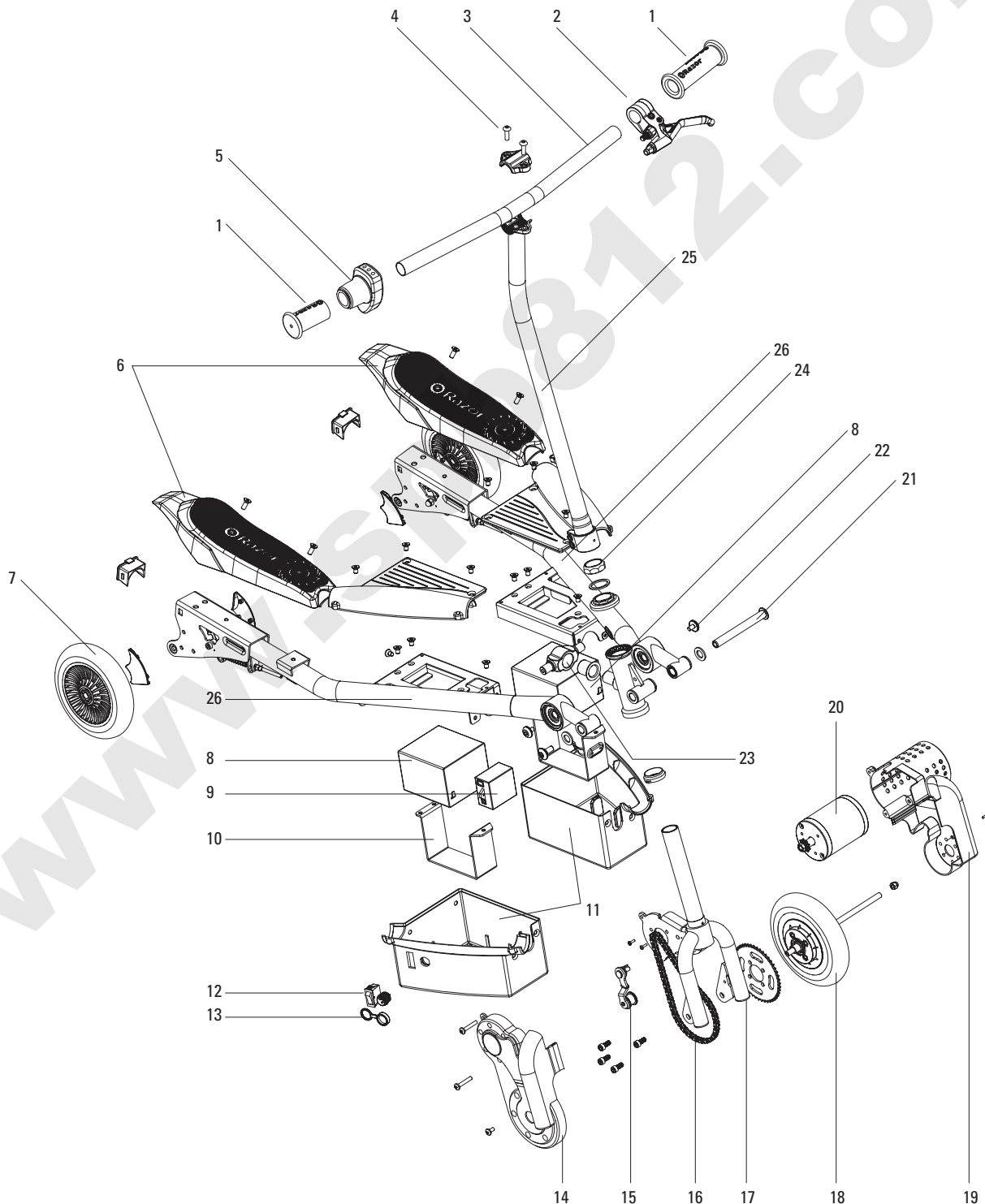

[www.spb812.com](http://www.spb812.com)

**SB 1918 (CALIFORNIA) DECLARATION**

YOUR INSURANCE POLICIES MAY NOT PROVIDE COVERAGE FOR ACCIDENTS INVOLVING THE USE OF THIS SCOOTER/ELECTRIC RIDE-ON PRODUCT. TO DETERMINE IF COVERAGE IS PROVIDED, YOU SHOULD CONTACT YOUR INSURANCE COMPANY OR AGENT.

[www.spb812.com](http://www.spb812.com)



**DO NOT RETURN TO STORE**  
Failure to follow these instructions may damage  
your product and void your warranty.

## WARRANTY

### Razor Limited Warranty

The manufacturer warrants this product to be free of manufacturing defects for a period of 90 days from date of purchase. This Limited Warranty does not cover normal wear and tear, wheels, tubes, cables, or any damage, failure or loss caused by improper assembly, maintenance, or storage or use of the Razor Trikke E2.

This Limited Warranty will be void if the product is ever:

- used in a manner other than for recreation;
- modified in any way;
- rented.

The manufacturer is not liable for incidental or consequential loss or damage due directly or indirectly to the use of this product.

Razor does not offer an extended warranty. If you have purchased an extended warranty, it must be honored by the store at which it was purchased.

For your records, save your original sales receipt with this manual and write the serial number below.

---

Printed in China for:  
Razor USA LLC  
PO Box 3610  
Cerritos, CA 90703

Copyright © 2003-2012 Razor USA, LLC. All rights reserved. RAZOR and the Razor Logo Design are among the registered trademarks of Razor USA LLC in the United States and/or select foreign countries. The Trikke technology is patented in the United States and select foreign countries by Trikke Tech, Inc. and licensed to Razor USA LLC for this product. Trikke is a registered trademark of the Trikke Tech, Inc. in the United States and select foreign countries, and is licensed to Razor USA LLC for this product.